



Zertifiziert nach ISO 9001



Pressure booster with feed tank BESV maximat MX1

*Cool down.
Fire Protection by*

MINIMAX

Product

- ▶ When using this extinguishing water system the water supply line is „wet“ (filled with extinguishing water) indirectly connected by means of an open feed tank with free outlet to the drinking water supply. In case of emergency when actuating the hose connection valve of a wall hydrant (extinguishing water request) the pressure booster is activated and the wall hydrant station supplied with the necessary water quantity with continuous pressure. In case of extinction the DVGW-certified float valve guarantees big out-flow rates with low loss of pressure as well as low pressure fluctuations and thus establishes the indirect connection from the drinking water supply to the fire extinguishing system. After termination of the extinguishing water request (closure of the hose connection valve), the pump resets automatically to the armed state.

Application

- ▶ The pressure booster with feed tank maximat MX1 is applicable as well in the scope of new installation as for system separation of existing extinguishing water plants acc. to DN 14462 and DIN 1988-600.
 - ▶ Typical application areas without frost risk are:
 - high-rise buildings
 - places of public assembly
 - hospitals
 - shops
 - blocks of offices
 - schools
- Application in areas, which are threatened by frost, is possible in conjunction with maximat FSX-LWT.
- ▶ The construction of the plant is effected each object-related in consideration of the piping network isometry, the resulting mathematical proof and all further technical requirements.

Your advantages

- ▶ long-life cycle due to high-quality materials
- ▶ the modular construction allows high flexibility in the installation phase with minimum required space. The access is limited to one side. Therefore optimal space exploitation
- ▶ suitability in terms of fire protection by VdS approved and in terms of drinking water by DVGW certified components:
 - free outlet (complete steel cylinder unit maximat BESV)*
 - float valve*
 - rinsing device*
 Thereby application also possible in fire load areas.
- ▶ simple expert acceptance due to VdS-approved and DVGW-certified* components
- ▶ The aerodynamic construction of the float valve assures high flow rates with low loss of pressure
- ▶ damaging vibrations and pressure surges in the piping are avoided by means of the high mass inertia of the floater and the application of a shut-off flap as inflow control fittings
- ▶ an especially developed control cabinet for this case of operation with potential-free contacts and control and retransmission possibilities to the building control system
- ▶ high maintainability due to easy accessibility of all armatures and control elements

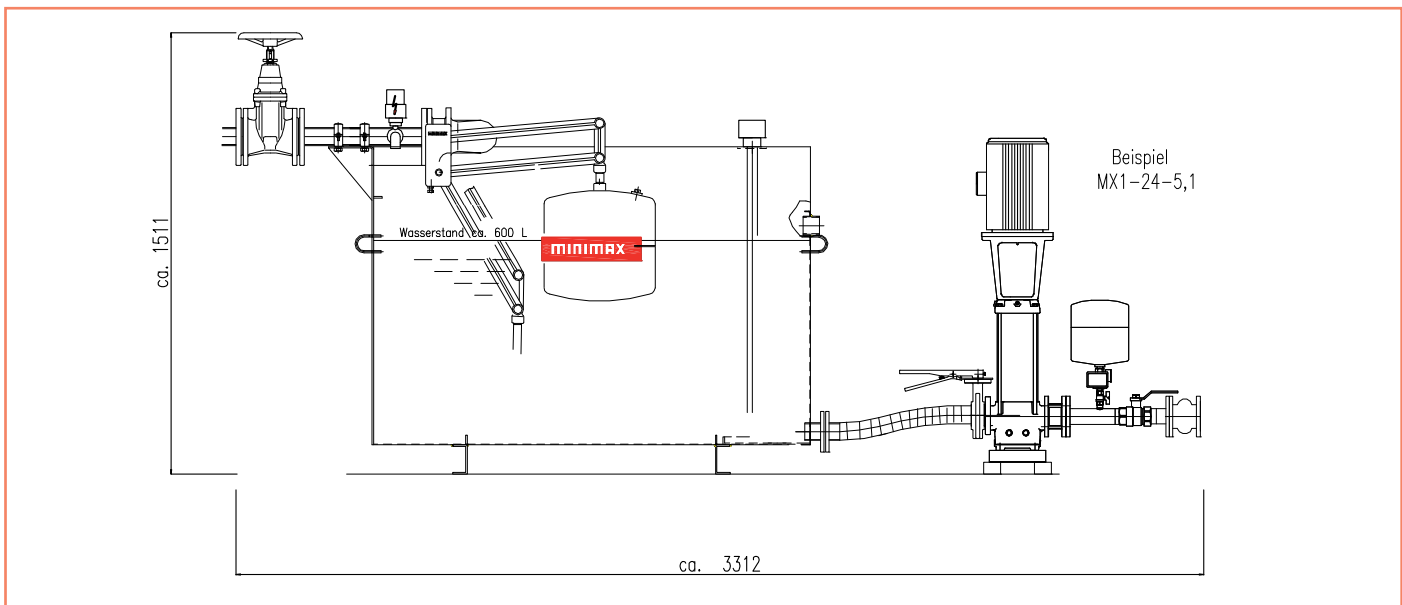

Technical data

- ▶ container unpressurized, welded out of steel
- ▶ for 600L net volume: L1745 x B616 x H1120 mm
- ▶ Float valve VdS-approved and DVGW-certified with KV Wert (l/min) 1000 nominal pressure PN10
- ▶ VdS-approval-no.: G-4880060/G-4960035
- ▶ *DVGW-registration-no.: DW-0903AQ2013 for float valve
DVGW-registration-no.: NW-6102BS0359 for rinsing device
DVGW-registration-no.: NW-0402CL0020 for free outlet

Scope of delivery

- ▶ Open, sand blasted, interiorly coated with tar epoxy feed tank out of steel with free outlet, with non-circular overflow (unlimited) of family A in the colour RAL 3000 with a hand-over point acc. to EN 1717
- ▶ Cover with steel cap in the color RAL 3000
- ▶ compact construction, ready-for-use tubed and wired
- ▶ VdS-approved and DVGW-certified float valve and stop valve
- ▶ 3-bar electrode for filling level control
- ▶ optional: feed hopper/outlet funnel

Service

- ▶ The construction of the plant is effected each object-related in consideration of the piping network isometry, the resulting mathematical proof and all further technical requirements.
- ▶ Your Minimax service takes over all works for inspection, maintenance and repair.

Special vanishing as well as other container dimensions and special geometries on request

Range examples of pressure booster of MX1

description	nominal voltage	P2 [kW]	In [A]	Q nenn [m³/h]	Q max [m³/h]	H nenn [m]	H null [m]	nominal width
MX 1-3-5,3	3 x 380-415 V	1,1	4,5	3	4,5	53	73	DN25 (PN16)
MX 1-3-5,7	3 x 380-415 V	1,5	4,5	3	4,5	57	79	DN25 (PN16)
MX 1-18-4,2	3 x 380-415 V	4	8	18	23	42	58	DN50 (PN16)
MX 1-18-5,2	3 x 380-415 V	4	8	18	23	52	71	DN50 (PN16)
MX 1-18-6,5	3 x 380-415 V	5,5	11,2	18	23	65	83	DN50 (PN16)
MX 1-24-5,1	3 x 380-415 V	5,5	11,2	24	29	51	73	DN50 (PN16)
MX 1-24-6,3	3 x 380-415 V	7,5	15,2	24	29	63	88	DN50 (PN16)
MX 1-24-7,3	3 x 380-415 V	7,5	15,2	24	29	73	102	DN50 (PN16)
MX 1-36-4,2	3 x 380-415 V	7,5	15,2	36	40	42	71	DN65 (PN16)
MX 1-36-4,9	3 x 380-415 V	7,5	15,2	36	40	49	78	DN65 (PN16)
MX 1-36-5,6	3 x 380-415 V	11	21,4	36	40	56	90	DN65 (PN16)
MX 1-36-6,3	3 x 380-415 V	11	21,4	36	40	63	98	DN65 (PN16)
MX 1-48-4,9	3 x 380-415 V	11	21,4	48	58	49	65	DN80 (PN16)
MX 1-48-5,6	3 x 380-415 V	11	21,4	48	58	56	78	DN80 (PN16)
MX 1-48-6,8	3 x 380-415 V	15	26,5	48	58	68	92	DN80 (PN16)
MX 1-72-5,4	3 x 380-415 V	15	26,5	72	85	54	80	DN100 (PN16)
MX 1-72-6,2	3 x 380-415 V	18,5	31,5	72	85	62	90	DN100 (PN16)
MX 1-72-6,8	3 x 380-415 V	18,5	31,5	72	85	68	98	DN100 (PN16)
MX 1-96-4,0	3 x 380-415 V	15	26,5	96	120	40	68	DN100 (PN16)
MX 1-96-4,7	3 x 380-415 V	18,5	31,5	96	120	47	82	DN100 (PN16)
MX 1-96-6,1	3 x 380-415 V	22	38,5	96	120	61	102	DN100 (PN16)