



Zertifiziert nach ISO 9001



Filling and drainage station

maximat FuE1 DN 50/DN 80

*Cool down.
Fire Protection by*

MINIMAX

Product

▶ When using this extinguishing water system „wet/dry“ the dry extinguishing water conduit is directly connected to the drinking water supply by means of the filling and drainage station maximat FuE1 in the dimensions DN50 or DN80. In case of operation when actuating the hose connection valve of a wall hydrant (extinguishing water request) the filling and drainage station is activated, and after maximal 60 seconds extinguishing water in sufficient quantity and with sufficient pressure is available on every wall hydrant. After termination of the extinguishing water request (closure of the hose connection valve), the extinguishing water conduit drains self-actuating by means of the filling and drainage station.

Application

- ▶ The filling and drainage station FuE1 is applicable as well in the scope of new installation as for system separation of existing extinguishing water plants acc. to DN 14462 and DIN 1988-600.
- ▶ Typical application areas are:
 - parking garages
 - outdoor areas
 - underground parking
 - storage areas
 - public areas as e.g. railway stations
 - other areas threatened by frost
- ▶ The construction of the plant is effected each object-related in consideration of the piping network isometry, the resulting mathematical proof and all further technical requirements.

Your advantages

- ▶ long-life cycle due to high-quality materials
- ▶ due to compressed air controlled drive no stagnation water = “Where’s no water, there’s no stagnation”
- ▶ low place requirement
- ▶ simple expert acceptance due to VdS-approved and DVGW-certified components
- ▶ In case of power failure at least 60 hours extinguishing water disposition independent of outside energy
- ▶ aerodynamic construction of the DVGW-certified and VdS-approved whole valves, adapted to the current market requirements of the water providers
- ▶ an especially developed control cabinet for this case of operation control and retransmission possibilities to the building control system
- ▶ low maintenance costs due to actuator without membrane as well as good accessibility of all valve parts and control elements
- ▶ high quality standard by means of control from the fire-alarm systems

Function



Scope of delivery

The filling and drainage station acc. to DIN 14463-1 with DVGW-certification and VdS-approval consists of the following components:

- ▶ optional: gate valve
- ▶ backflow preventer
- ▶ isolation valves
- ▶ control electronics type GAB6 72 NSV/ type MOD S

Maintenance

- ▶ The construction of the plant is effected each object-related in consideration of the piping network isometry, the resulting mathematical proof and all further technical requirements.
- ▶ Your Minimax Service takes over all works for inspection, maintenance and repair.

Technical data

- ▶ operating voltage: 230 V
control voltage: 24 VDC
frequency: 50 Hz
- ▶ equivalent length DN 80: 14,5 m
loss pressure DN 80: 0,43 bar bei 1630 l/mi
- ▶ control electronics
type: GAB6 72 NSV with
VdS-approval-no.: G-298006
regulations: EN54-2, -4; VDE0833; DIN 14463-1
- ▶ DVGW-registration-no.: NW-9910BT0532

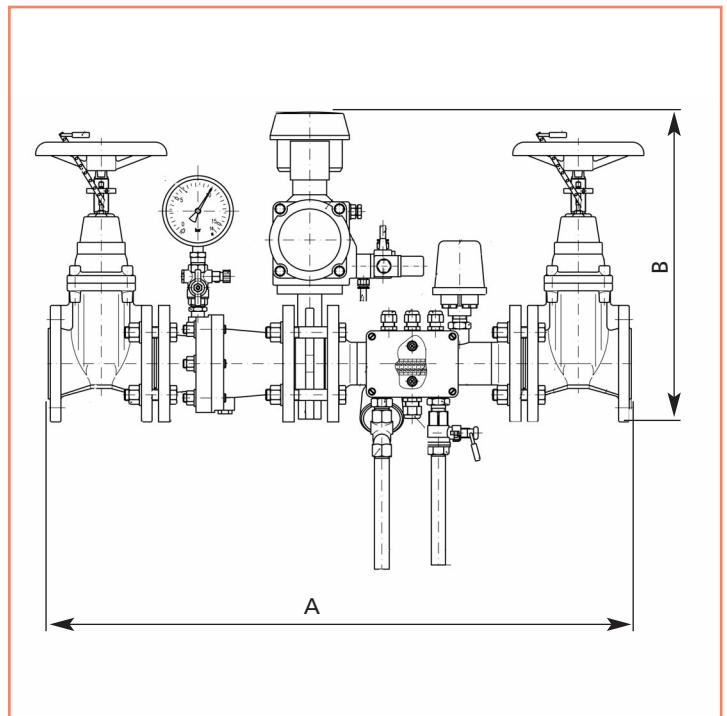

FuE 1	length (A)	height (B)	depth
DN50	810 mm	660 mm	210 mm
DN80	960 mm	735 mm	290 mm



Das Unternehmen ist gemäß ISO 14001:2004 zertifiziert.

Minimax Mobile Services GmbH & Co. KG
Minimaxstraße 1 | D-72574 Bad Urach
Tel.: +49 7125 154-0 | Fax: +49 7125 154-100
E-Mail: mobile@minimax.de | www.minimax.de
www.minimax-mobile.com

Minimax Brandschutzcenter Hamburg
Competence Center Löschwassertechnik
Osterrade 23 | D-21031 Hamburg
Tel.: +49 40 251966-20 | Fax: +49 40 251966-19
E-Mail: loeschwassertechnik@minimax.de