

## Filling and drainage station

### maximat FSX LWT DN 50/80/100

*Cool down.  
Fire Protection by*

**MINIMAX**

#### Product

▶ When using this extinguishing water system „wet/dry“ the extinguishing water conduit is dry. The extinguishing water volume, which is provided by the drinking water supply does not suffice in order to fill the extinguishing water pipework with water within 60 seconds. Therefore the filling volume must be stored in a feed tank. After actuating the hose connection valve of a wall hydrant (extinguishing water request) the filling and drainage station with the pressure booster is activated, and after maximal 60 seconds extinguishing water in sufficient quantity and with sufficient pressure is available on every wall hydrant. After termination of the extinguishing water request (closure of the hose connection valve), the extinguishing water conduit drains automatically by means of the filling and drainage station.

#### Application

- ▶ The maximat FSX LWT is applicable as well in the scope of new installation as for system separation of existing extinguishing water plants acc. to DN 14462.
- ▶ Typical application areas are:
  - parking garages
  - outdoor areas
  - underground parking
  - storage areas
  - public areas as e.g. railway stations
  - other areas threatened by frost
- ▶ Application only in conjunction with the pressure booster maximat MX1.
- ▶ The construction of the plant is effected each object-related in consideration of the piping network isometry, the resulting mathematical proof and all further technical requirements.

#### Your advantages

- ▶ long-life cycle due to high-quality materials
- ▶ the modular construction allows high flexibility in the installation phase with minimum required space
- ▶ The aerodynamic construction of the fittings guarantees high flow rates with low loss of pressure
- ▶ damaging vibrations and pressure surges in the piping are avoided by means of the high mass inertia of the floater
- ▶ an especially developed control cabinet for this case of operation with control and retransmission possibilities to the building control system
- ▶ high maintainability due to easy accessibility of all armatures and control elements
- ▶ simple expert acceptance due to VdS approved components
- ▶ suitability in terms of fire protection by VdS approved fittings and steel container, thereby application also possible in fire load areas
- ▶ low-priced because no DVGW-certification necessary

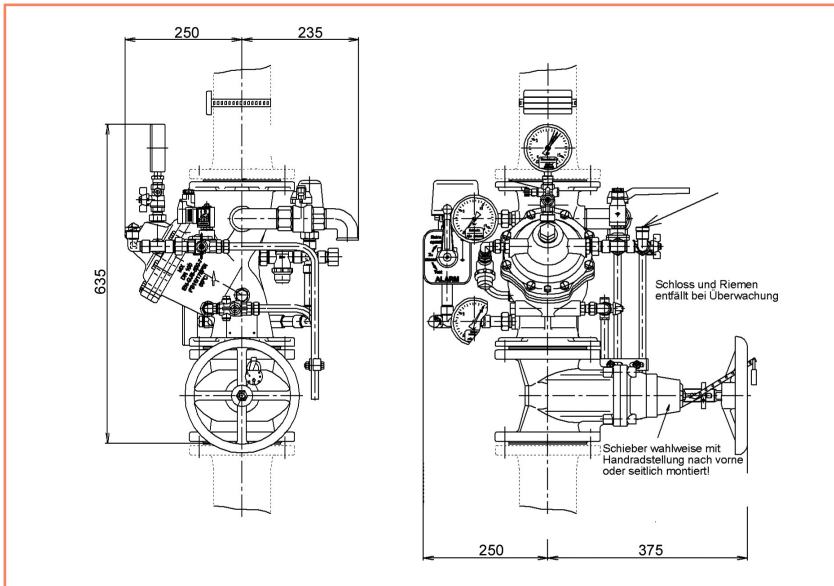

## Technical data

- ▶ operating pressure max. PS16
- ▶ water supply pressure:
  - min. 2 bar bis 5 m/s flow rate
  - min. 2,5 bar bis 5-7 m/s flow rate
  - min. 3,0 bar bis 7-8 m/s flow rate
  - min. 3,8 bar bis 8-10 m/s flow rate
- ▶ electrical release 24 V DC 2/2-way-solenoid valve
- ▶ alarm (pressure switch PMA-3):
  - potential-free contacts – 1 opener, 1 closer
  - ampacity 6A-250V VAC, 5A-24VDC
- ▶ operating temperature max. 60°C
- ▶ equivalent length DN 50 - 3,1 m (pipe 60,3 x 2,9)
- ▶ equivalent length DN 80 - 7,1 m (pipe 88,9 x 2,9)
- ▶ equivalent length DN 100 - 12 m (pipe 114,0 x 3,2)

## Scope of delivery

The filling and drainage station FSX-LWT with feed tank and pressure booster consists of the following components:

- ▶ filling and drainage station VdS-approved, for application in the non drinking water area with complementary control units
- ▶ pressure booster with feed tank maximat MX1 (see separate product data sheet)

## Service

- ▶ The construction of the plant is effected each object-related in consideration of the piping network isometry, the resulting mathematical proof and all further technical requirements.
- ▶ Your Minimax service takes over all works for inspection, maintenance and repair.

## Range of pressure booster of MX1

description	nominal voltage	P2 [kW]	In [A]	Q nenn [m³/h]	Q max [m³/h]	H nenn [m]	H null [m]	nominal width
MX 1-3-5,3	3 x 380-415 V	1,1	4,5	3	4,5	53	73	DN25 (PN16)
MX 1-3-5,7	3 x 380-415 V	1,5	4,5	3	4,5	57	79	DN25 (PN16)
MX 1-18-4,2	3 x 380-415 V	4	8	18	23	42	58	DN50 (PN16)
MX 1-18-5,2	3 x 380-415 V	4	8	18	23	52	71	DN50 (PN16)
MX 1-18-6,5	3 x 380-415 V	5,5	11,2	18	23	65	83	DN50 (PN16)
MX 1-24-5,1	3 x 380-415 V	5,5	11,2	24	29	51	73	DN50 (PN16)
MX 1-24-6,3	3 x 380-415 V	7,5	15,2	24	29	63	88	DN50 (PN16)
MX 1-24-7,3	3 x 380-415 V	7,5	15,2	24	29	73	102	DN50 (PN16)
MX 1-36-4,2	3 x 380-415 V	7,5	15,2	36	40	42	71	DN65 (PN16)
MX 1-36-4,9	3 x 380-415 V	7,5	15,2	36	40	49	78	DN65 (PN16)
MX 1-36-5,6	3 x 380-415 V	11	21,4	36	40	56	90	DN65 (PN16)
MX 1-36-6,3	3 x 380-415 V	11	21,4	36	40	63	98	DN65 (PN16)
MX 1-48-4,9	3 x 380-415 V	11	21,4	48	58	49	65	DN80 (PN16)
MX 1-48-5,6	3 x 380-415 V	11	21,4	48	58	56	78	DN80 (PN16)
MX 1-48-6,8	3 x 380-415 V	15	26,5	48	58	68	92	DN80 (PN16)
MX 1-72-5,4	3 x 380-415 V	15	26,5	72	85	54	80	DN100 (PN16)
MX 1-72-6,2	3 x 380-415 V	18,5	31,5	72	85	62	90	DN100 (PN16)
MX 1-72-6,8	3 x 380-415 V	18,5	31,5	72	85	68	98	DN100 (PN16)
MX 1-96-4,0	3 x 380-415 V	15	26,5	96	120	40	68	DN100 (PN16)
MX 1-96-4,7	3 x 380-415 V	18,5	31,5	96	120	47	82	DN100 (PN16)
MX 1-96-6,1	3 x 380-415 V	22	38,5	96	120	61	102	DN100 (PN16)