

MINIMAX

MOBILE SERVICES

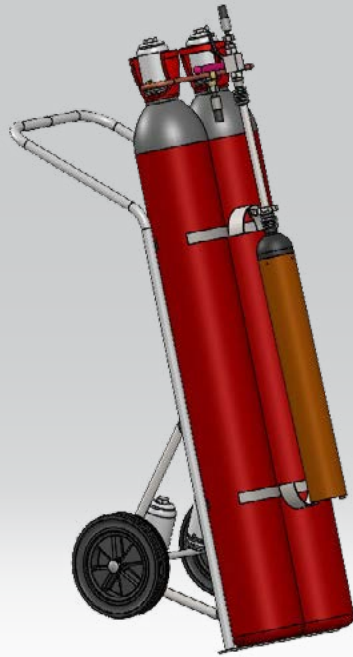

CARBON DIOXIDE EXTINGUISHING UNIT

C 60

PRODUCT

- ▶ Fire extinguishing units with carbon dioxide as a natural extinguishing agent are an ideal instrument for fighting B-class fires.

The extinguishing effect is based on the suffocation effect of the carbon dioxide, which guarantees completely residue-free extinguishing and which is not electrically conductive.

RANGE OF APPLICATION

- ▶ The extinguishing gas carbon dioxide is used wherever fires of liquid substances or substances becoming liquid are fought.
- ▶ Typical ranges of application are:
 - electrical and electronic systems
 - super-clean and clean rooms
 - chemical industry
 - areas with special hygienic requirements
 - machines and systems
 - paint shops

YOUR ADVANTAGES

- ▶ No extinguishing agent residues
- ▶ Very high extinguishing efficiency
- ▶ Easy to handle and operate
- ▶ Easy to proportion with an extinguishing jet, which can be stopped at any time
- ▶ High operating safety
- ▶ Easy to maintain
- ▶ Easy to transport
- ▶ Environmentally friendly



OPERATION AND FUNCTION

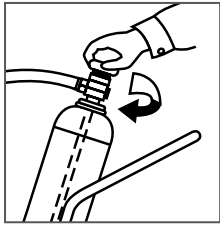

Take snow pipe device out of the support and lay out entire extinguishing hose without bends. Open rotary valve(s).

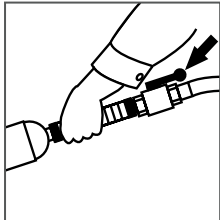

Open stop valve and aim snow pipe at the fire source.

- ▶ After laying out the extinguishing hose and opening the rotary valve(s) the extinguishing gas flows into the extinguishing hose and is then discharged through the snow pipe if the stop valve is opened. The extinguishing agent flow can be stopped any at time by using the stop valve.
- ▶ After extinguishing: Close rotary valve(s), fasten snow pipe and extinguishing hose in the support again. The gas cylinder(s) must be refilled immediately after use even if not completely emptied to guarantee availability.

TECHNICAL DATA

Type	Carriage	Extinguishant cylinders*	Cylinder design	Release	Fire fighting device
C60	Steel tube, black, RAL 9005, tyres: disk wheels, solid-rubber tyres, steel tube with cylinder, support for fire fighting device	With 2x gas cylinders à 30 kg CO ₂ , RAL 3000	Type approved rotary valve according to pressure vessel regulation rules, riser, excess pressure safety device, transport protection cap	System release manual via rotary valves, connection via manifold	Snow pipe, extension piece with rubber grip, stop valve, 6 m high-pressure extinguishing hose

* Gas cylinders that are type approved according to regulation 2010/35/EU are used as extinguishant cylinders.

Type	Official approval class number	Extinguishant quantityl kg	Extinguishant agent	Test cylinder pressure bar	Operating pressure at +20 °C approx. bar	Discharge rate at room temperature approx. kg/s	Spraying width approx. m	Temperature range °C	Fire classification	Dimensions			Weight approx. kg
										Width approx. mm	Height approx. mm	Length approx. mm	
C60	P 3-11/58	60	Carbon dioxide	250	58	1	3	-20 to +60	B	640	1,700	1,250	180

Subject to technical alterations.

Follow Minimax Mobile Services on [LinkedIn](#), [Instagram](#), [Facebook](#) and [Youtube](#).

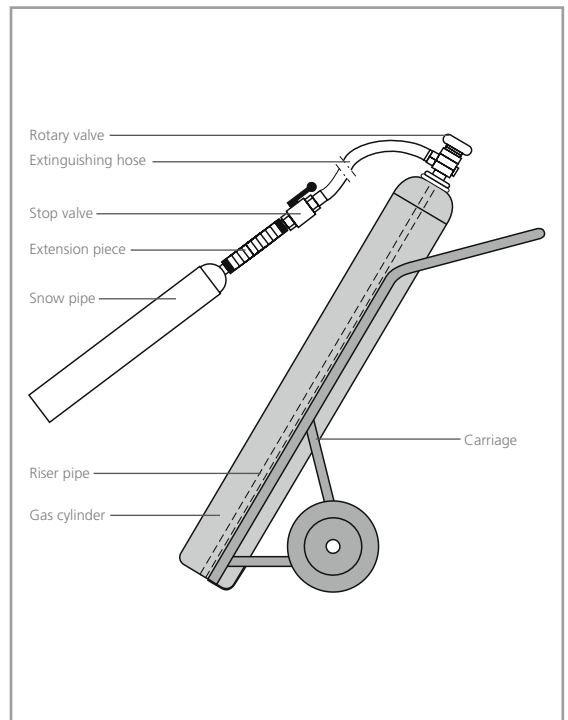

MAINTENANCE

- ▶ Fire extinguishing units must be maintained and serviced in regular intervals by qualified experts.
- ▶ Minimax Service takes over all inspection and filling services. Contact your local agent.
- ▶ Suitable for up to 1,000 volt observing a minimum distance of 1 m, for more than 1,000 volt observe DIN VDE 0132.
- ▶ Please observe the characteristics of the extinguishing agent CO₂. Caution when using CO₂ in narrow rooms that are difficult to ventilate!
- ▶ Liquid fires must be extinguished without interrupting the extinguishing process!

Minimax Mobile Services GmbH
 Export Department
 Minimaxstraße 1
 D-72574 Bad Urach
 Tel.: +49 (0)7125 154-216
 Fax: +49 (0)7125 154-166
 E-Mail: zentrale@minimax.de
www.minimax-mobile.com



PB01 FG April 2026